

龙门式  
立卧转换加工中心  
FIXED GANTRY  
VERTICAL-HORIZONTAL  
MACHINING CENTER

**D**系列  
D SERIES



**C.B.Ferrari**

ITALIAN EXCELLENCE SINCE 1966

## 公司历史 OUR HISTORY

- 1966** 1966年9月1日 C.B.Ferrari公司在位于意大利米兰北部50公里处的瓦雷泽省莫尔纳戈成立。三位创始人分别是负责技术的Renato Bianchi先生和Giuseppe Ferrari先生，以及负责财务的Augusto Caravati先生。成立之初的目标方向是生产适用于加工冲头、模具和复杂零件的小型铣床。  
*C.B.Ferrari is established September 1st in the northern Italian town of Mornago (VA), 50 km north from Milan, by Mr. Renato Bianchi and Mr. Giuseppe Ferrari as technical members and Mr. Augusto Caravati as the financial member and begin the production of small milling machines suited to build punches, moulds and complex workpieces.*
- 1967** C.B.Ferrari 公司研发了自己的直流电机和驱动系统，并生产了第一台直流电机驱动的三轴机床。  
*C.B.Ferrari develops its own DC motors and drives, builds the first 3-Axis machine operated by DC motors.*
- 1973** C.B.Ferrari 为生产的绝大多数机床配备了数控系统并且采用了绝对测量系统。  
*C.B.Ferrari equips the majority of its machines with CNC and adopts absolute measuring systems.*
- 1974** C.B.Ferrari 发布了机床热补偿软件。  
*C.B.Ferrari releases the machines thermal compensation software.*
- 1978** C.B.Ferrari 制造了自己的第一个双摆转台和第一台五轴加工中心。  
*C.B.Ferrari builds its own first 2-Axis rotary table and builds its first 5-Axis machine.*
- 1984** C.B.Ferrari 创立了软件技术部以开发自己的CAM软件。  
*C.B.Ferrari founds Tecnosoft, its CAM software division.*
- 1985** 软件技术部发布了第一版3D CAM软件。  
C.B.Ferrari 和意大利领先的Elexa公司共同研发了第一套基于PC的数控系统。  
*Tecnosoft releases its first 3D CAM software.  
C.B.Ferrari develops the first PC-based CNC in Europe, in cooperation with the Italian CNC leading company Elexa.*
- 1987** C.B.Ferrari 在意大利摩德纳建立了新工厂。  
*C.B.Ferrari opens a new plant in Modena (Italy).*
- 1992** C.B.Ferrari 自主研发并生产了第一根电主轴。  
*C.B.Ferrari builds its own first electro-spindle.*
- 1993** 软件技术部发布了专门应用于透平叶片制造的CAM软件。  
*Tecnosoft releases the CAM software for turbine blades machining.*
- 1994** C.B.Ferrari 售出了第一台用于发电机叶片加工的机床。  
*C.B.Ferrari sells the first machine for power-generation blades manufacturing.*
- 1998** 软件技术部发布了用于模拟加工过程的数字仿真软件。  
C.B.Ferrari 售出了第一台用于航空发动机叶片加工的机床。  
*Tecnosoft releases the software for machining's graphical simulation.  
C.B.Ferrari sells the first machine for aero-engine blades manufacturing.*
- 2003** C.B.Ferrari 生产了第一台配置直线电机和力矩电机的立式五轴加工中心。  
*C.B.Ferrari builds its first vertical 5-Axis Machine equipped with linear and torque motors.*
- 2008** 软件技术部发布了用于分析和优化机床性能表现的软件。  
*Tecnosoft introduces Dynamic Analysis and Tuning software.*
- 2009** C.B.Ferrari 成立了激光技术部。  
*C.B.Ferrari establish its own Laser Division.*
- 2010** 软件技术部改进了CAM软件，使其能够适用于整体叶盘和叶轮的加工。  
*Tecnosoft develops the CAM software for IBR's (blisks) and Impellers machining.*
- 2012** C.B.Ferrari 生产了第一台配有直线电机和力矩电机的卧式五轴加工中心。  
C.B.Ferrari 和瑞士Rofin Lasag 公司在激光技术应用领域签署独家协议。  
*C.B.Ferrari builds its first horizontal 5-Axis Machine equipped with linear and torque motors.  
C.B.Ferrari and Rofin Lasag sign an exclusive agreement for laser application development.*
- 2013** C.B.Ferrari 开发了适用于分度凸轮加工的机床与配套软件。  
*C.B.Ferrari develop machine and software for the cam machining.*
- 2015** C.B.Ferrari 发布了专为中型叶片加工而设计的N316机床。  
*C.B.Ferrari present the new N316 model for the medium size blades machining.*
- 2016** C.B.Ferrari 发布了专为超大型叶片加工而设计的N530机床，同年售出6台。  
*C.B.Ferrari present and supply 6 machines of the new model N530, for the machining of the biggest blades in the world.*



## 公司简介 THE COMPANY

### 传统与创新

伴随着自1966年起的不断突破、创新以及坚持对性能与精度的不懈追求，C.B.Ferrari 在广泛的加工应用领域内皆游刃有余，获得了市场的肯定与信任，这奠定了其在世界上高精度五轴加工中心生产商中的领导地位。

意大利是欧洲第二大机床生产国，也是世界第五大机床生产国。目前C.B.Ferrari在意大利运营两家工厂，共有170余名积极的高技术员工，在生产高精度机床上具备丰富的经验与优秀的传统，同时自主生产包含电主轴和旋转工作台在内的绝大多数机床部件，这一切使得C.B.Ferrari能保证产品优异的质量和可靠性。

C.B.Ferrari在世界范围内安装超过4500台机床，并就近提供及时的销售和售后服务。C.B.Ferrari确保客户能够获得极高水平的技术支持，并享受业内顶尖水准的机床性能与精度。

### TRADITION AND INNOVATION

*Since 1966 constant innovation, performance based approach and market recognized and consolidated superior accuracy, achieved in a wide variety of manufacturing applications, have led C.B.Ferrari to a world leading position in high precision 5-Axes CNC machining centers solutions.*

*Currently C.B.Ferrari operates with two manufacturing facilities in Italy, the second major machine manufacturing country in Europe and the fifth in the World. 170 skilled and highly motivated employees, enjoying the homeland long-standing tradition in precision mechanics, design and manufacture all machines in house including electro-spindles and rotary tables, ensuring extraordinary quality and reliability over the time.*

*With more than 4500 machines successfully installed worldwide, supported by a complete and prompt sales and service network, C.B.Ferrari ensures its customers the ultimate manufacturing support, achieving state-of-the-art results in terms of accuracy and performances.*



# 全面服务 *SERVICES*





## 服务内容 SERVICES



C.B.Ferrari 提供广泛的技术服务，包括：

- 全球范围的销售和服务网络
- 专有主轴、分度头的制造与维修
- **顶尖的专有CAM软件和仿真模拟软件**
- 交钥匙解决方案
- 机床操作示范及加工效率优化
- 精度和重复定位精度测试
- 定制自动化解决方案
- 机床大修
- 全面的技术培训



*C.B.Ferrari offers comprehensive consulting, including:*

- *Worldwide Sales and Service Network*
- *Proprietary Spindles and Dividing Heads Manufacturing and Repair*
- ***Proprietary CAM and Simulation Software products***
- *Turnkey Projects*
- *Machine Demonstration and Time Studies*
- *Accuracy and Repeatability Tests*
- *Customized Automation Solutions*
- *Used machines Overhauls*
- *Training programs*



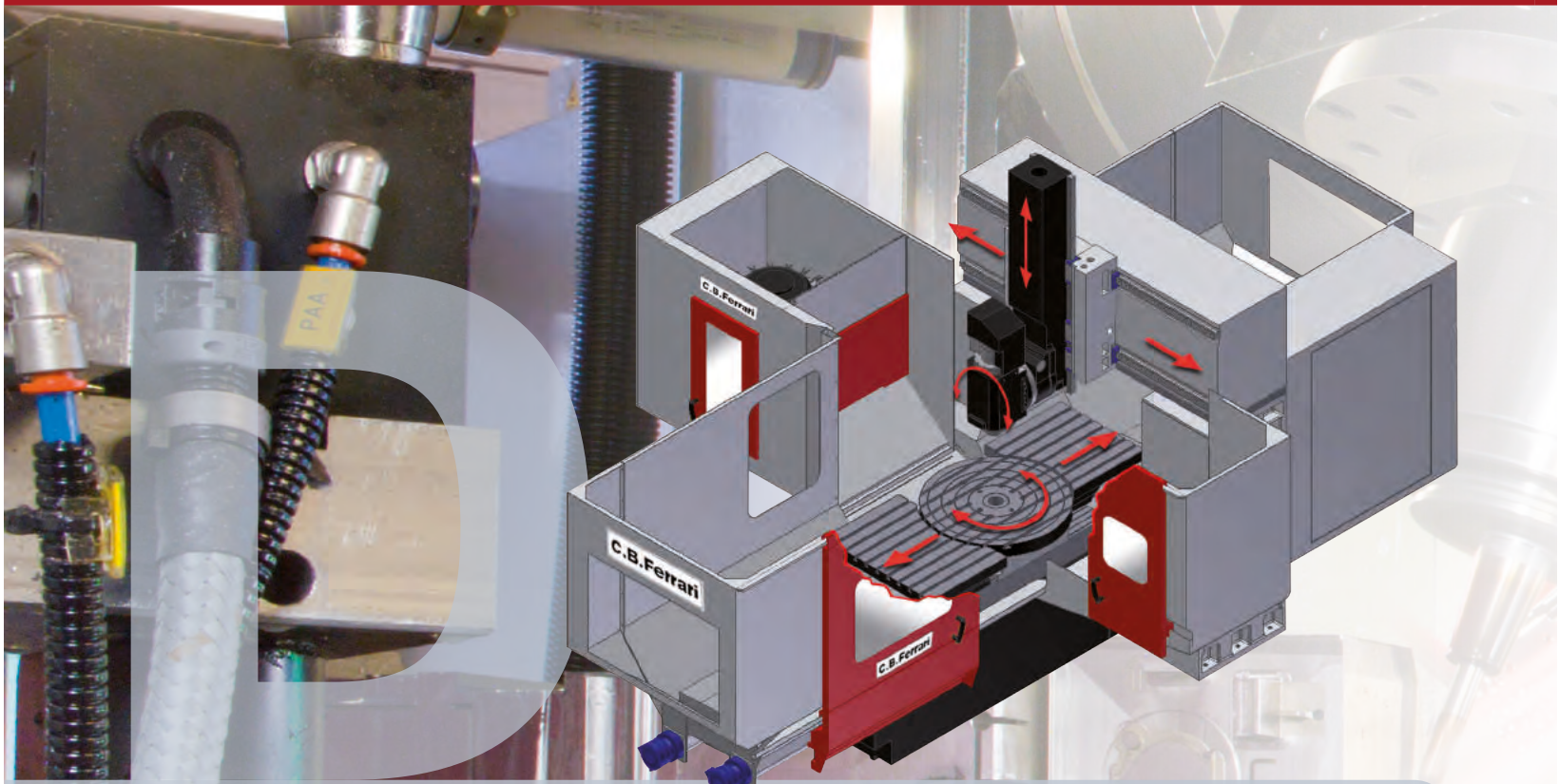

## D系列 - D SERIES

D系列机床包括一系列高速龙门式加工中心，刀具主轴实现Y、Z方向上的直线运动，工作台实现X方向上的直线运动，该系列特别适用于中大型零件的精密加工。

系列包含5个型号：D230，D420/22和D430/32，其主要区别在于工作区域的大小。

所有的D系列机器都可以配备一个连续摆动主轴头和一个旋转工作台，以分别实现4轴或5轴的联动。自主生产的各式电主轴可以满足最先进的加工技术在转速，扭矩和功率方面的要求。

在D422和D432型号上，可以通过配备由力矩电机驱动的双摆头以实现5轴联动。

D系列各直线轴的长行程使得不论是在水平方向上还是竖直方向上加工都轻而易举，可以对工件只进行一次装夹即可进行五个面的加工，在配有双摆头的D422和D432上，即使是较长的工件也游刃有余。

*The D-Series includes a full range of high-speed portal machining centers, with two linear axes of movement on the tool and one on the table, specifically designed for precision machining of medium-big sized pieces.*

*The range includes 5 models, D230, D420/22, D430/32, whose main differences relate to the slide travels range.*

*All the D-Series models can be equipped with a tilting head and a rotary table to realize the 4 or 5 axes configuration respectively. For these configurations a wide range of electrospindles is available, to meet the demands of the most advanced machining technologies for spindle speed, torque and power.*

*On the D422 and D432 models, the 5-Axes configuration can be also realized by installing a continuous bi-rotary tilting head with two torque axes.*

*The wide machine slide travels allow to perform machining both with vertical and horizontal tool axis, thus allowing machining of the 5 faces in one placement. In the configuration with bi-rotary head this possibility is also extended to long-shaped pieces.*





## 产品优势 ADVANTAGES

### 刚性铸铁结构

立式工作台的动柱式结构大大减少了机器的占地面积，而且更便于操作，同时确保了极佳的排屑性能。

### 5轴配置高载荷

配有连续摆动主轴头和旋转工作台的配置，载荷：3200Kg（3000kg-力矩电机）

配有双摆头的配置，载荷：5000Kg

### 高扭矩高转速的电主轴

在配有连续摆动主轴头和旋转工作台的配置中，可以安装更强劲的电主轴以同时满足粗加工和精加工的要求。

### 自动托盘交换系统

D系列可以集成自动化托盘交换系统，工件可以从机器的后部进入工作区，而不影响操作员的视野。

### STIFF CAST-IRON STRUCTURE

The manufacturing process, together with the stabilization treatment, provides the machine with precision and over time stability.

### HIGH LOADING CAPACITY ON 5-AXES

Configuration with continuous head and rotary table: 3200kg (3000kg with torque motor)  
Configuration with bi-rotary head: 5000 kg

### ELECTROSPINDLES WITH HIGH TORQUE AND SPEED

In the configuration with continuous head and rotary table it is possible to apply high power electrospindles to perform both roughing and finishing processes.

### AUTOMATIC PALLET CHANGE

It is possible to achieve extensive automatic pallet replacements, where pallets remain on the backside of the machine, without affecting the operator's view.



# 应用一览

## APPLICATION SECTORS



8

航空航天  
模具制造  
医用医疗  
汽车行业  
精密机械

AEROSPACE  
MOULDS AND DIES  
MEDICAL  
AUTOMOTIVE  
PRECISION MACHINERY

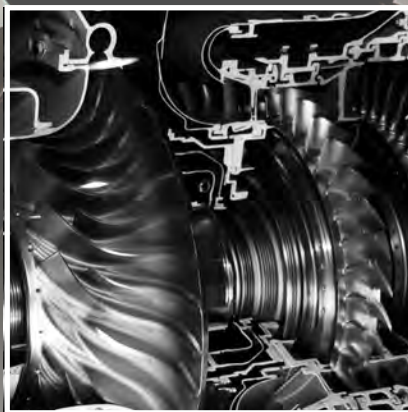



# 产品参数

## FEATURES

	D230	D420	D422	D430	D432
<b>行程 • SLIDE TRAVELS</b>					
X - 轴 Longitudinal (mm)	1600	2000	2000	3000	3000
Y - 轴 Cross (mm)	1600	1600	2200	1600	2200
Z - 轴 Vertical (mm)	820	1000			
Z - 可选 Vertical OPTION (mm)	1000	1100 - 1250			
<b>轴 • AXES</b>					
XYZ - 进给速度 Feed rates (m/min)	40	40	40	40	40
XY轴推力 Thrust XY (N)	19000	19000	19000	19000	19000
Z轴推力 Thrust Z (N)	10000	10000	10000	10000	10000
<b>轴向加速度 • AXES ACCELERATION</b>					
X - 线性加速度 Linear (m/s <sup>2</sup> )	2	2	2	2	2
YZ - 线性加速度 Linear (m/s <sup>2</sup> )	4	4	4	4	4
<b>测量系统 • MEASURING SYSTEM</b>					
绝对光栅尺 Absolute optical linear scales	Heidenhain				
<b>尺寸与重量 • WEIGHTS AND DIMENSIONS</b>					
尺寸 Dimensions (m)	6,2x6,2	6,35x7,3	6,35x7,3	8x7,3	8x7,3
高度 Height (m)	4,45	4,45	4,45	4,45	4,45
重量 Weight (kg)	16000	18000	19000	21000	22000
装机功率 Installed power (kW)	65	65	65	65	65
<b>刀库 • TOOLS MAGAZINE</b>					
<b>转盘式刀库 Movable wheel magazine type</b>					
刀位数量 Positions (V40-HSKA63/V50)	30/20	30/20	30/20	30/20	30/20
换刀时间 Changing time chips/chips (s)	10	10	12	10	12
刀具最大长度 Max. tool length (mm)	300	300	300	300	300
刀具最大直径 Max. Tool diameter (mm)	125/160	125/160	125/160	125/160	125/160
刀具最大重量 Max tool weight (kg)	8	8	8	8	8
<b>链条式刀库 Chain type</b>					
刀位数量 Positions (V40-HSKA63/V50)	60/40	60/40	60/40	60/40	60/40
换刀时间 Changing time chips/chips (s)	8	8	8	8	8
刀具最大长度 Max. tool length (mm)	290	290	290	290	290
刀具最大直径 Max. Tool diameter (mm)	78/110	78/110	78/110	78/110	78/110
刀具最大重量 Max tool weight (kg)	8	8	8	8	8
<b>机床精度 • POSITIONING TOLERANCES</b>					
P/Ps max 直线轴 Linear axes (μm)	6/4	8/6	8/6	10/8	10/8
P/Ps max 旋转轴 Rotary axes (")	6/4				

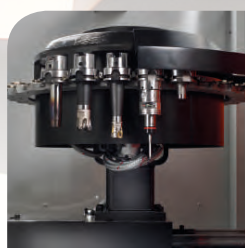

转盘式刀库  
Movable wheel magazine



链条式刀库  
Movable chain magazine



配有机械手的链条式刀库  
Chain magazine with exchanging arm

注：可配置HSKA100刀库，刀位数量可定制

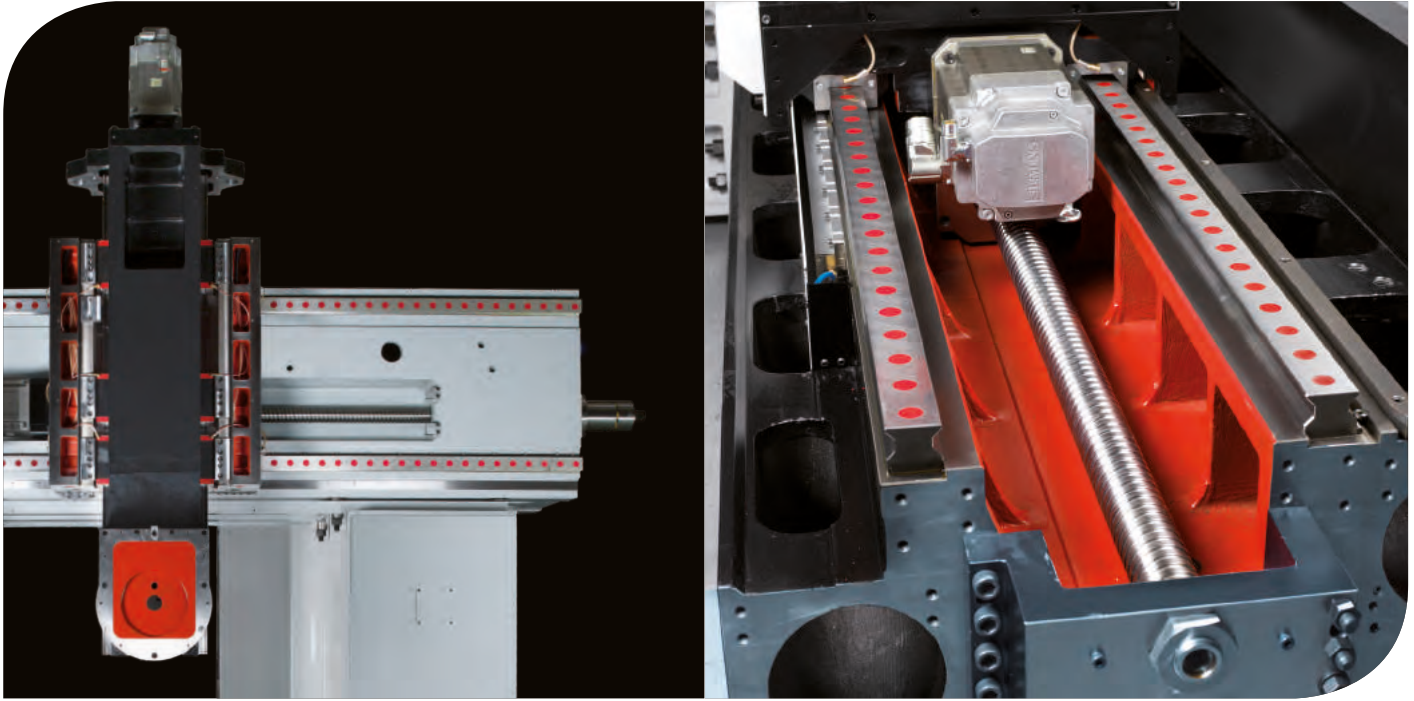

**D230**

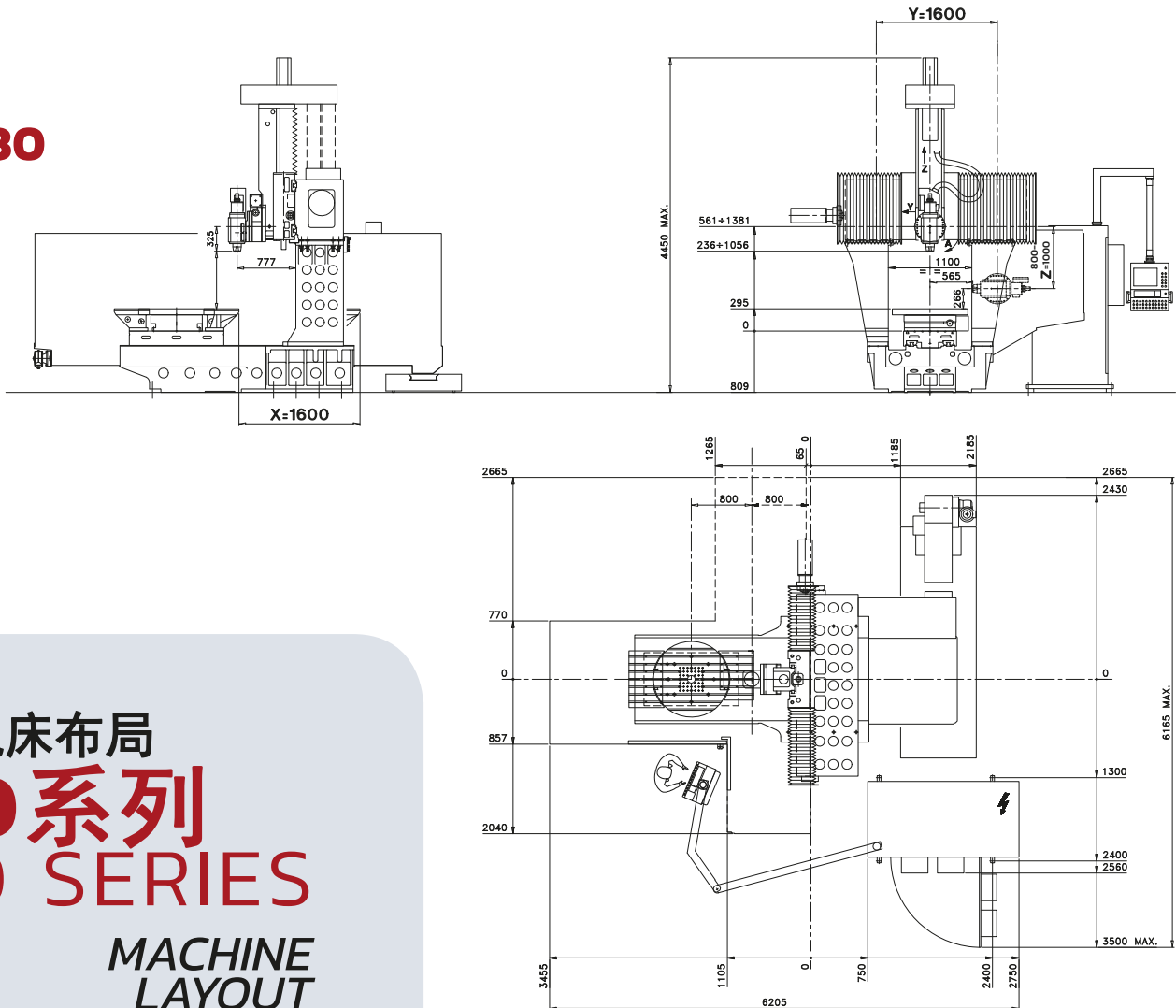

机床布局  
**D系列**  
**D SERIES**  
 MACHINE  
 LAYOUT



下列4个型号Z轴行程最大可达1250

# D420

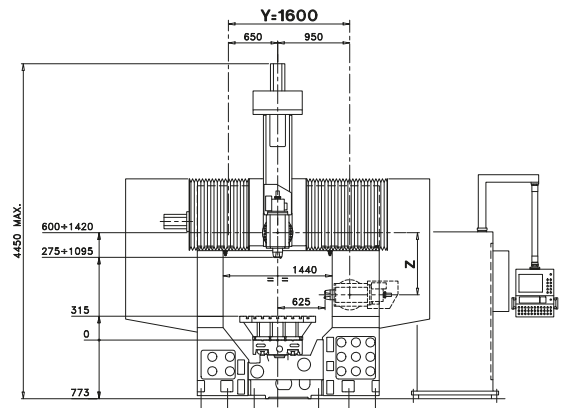
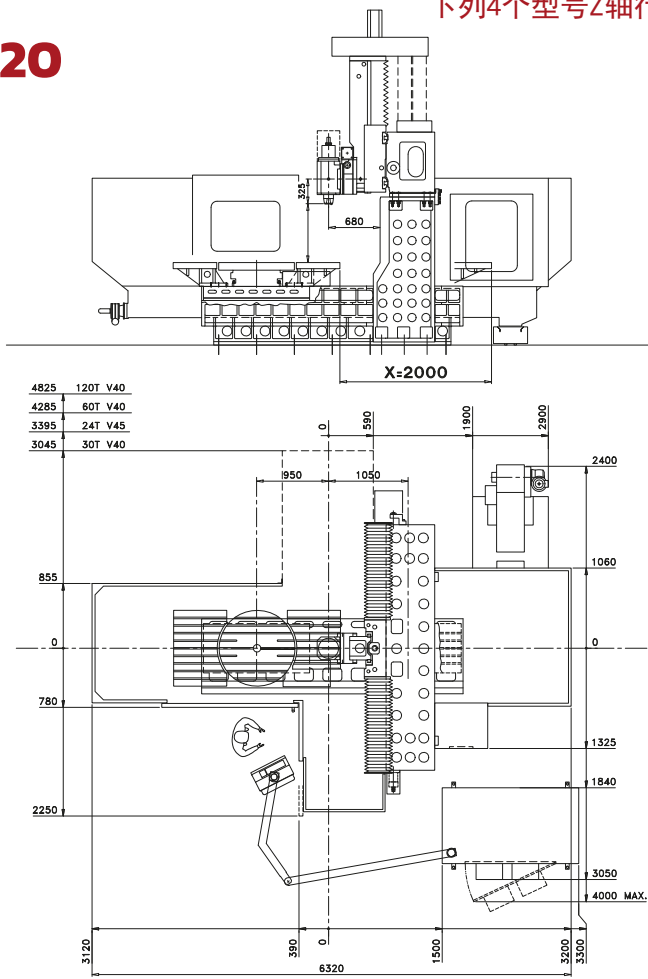

# D422

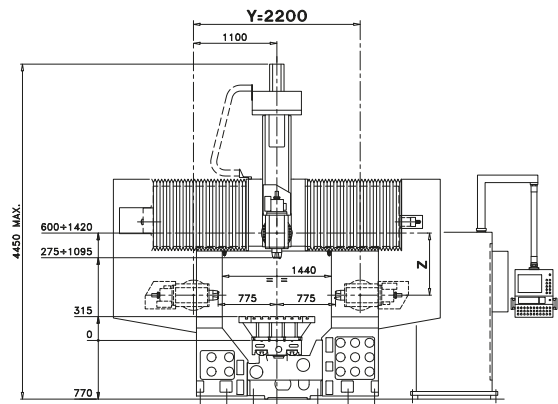
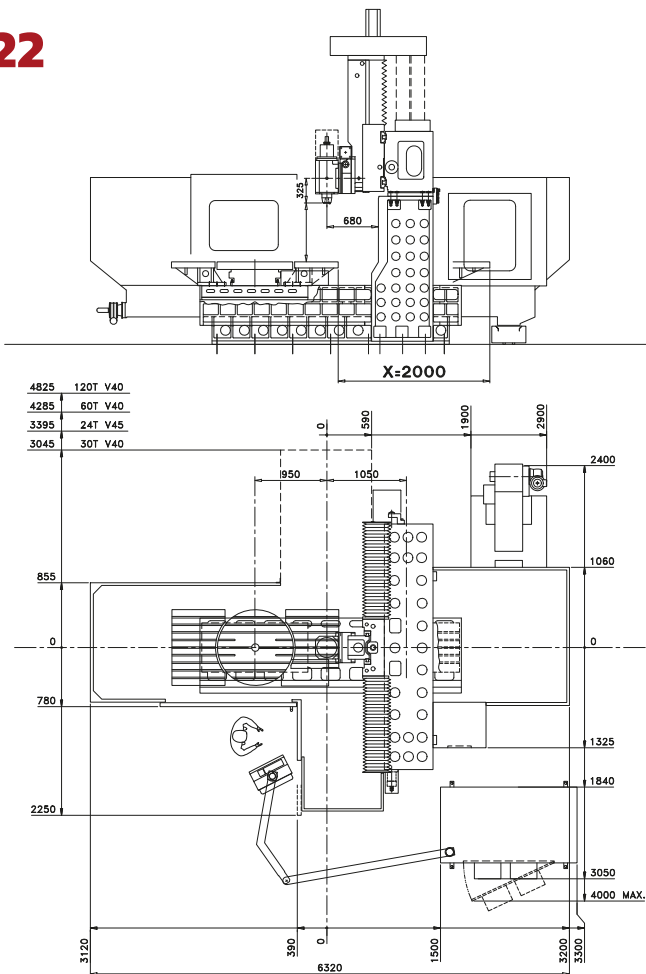

# D430

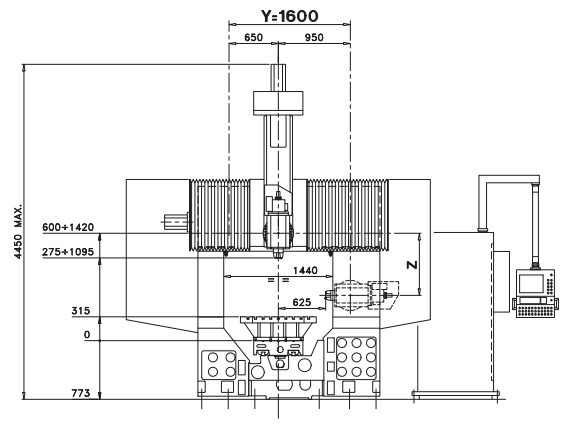
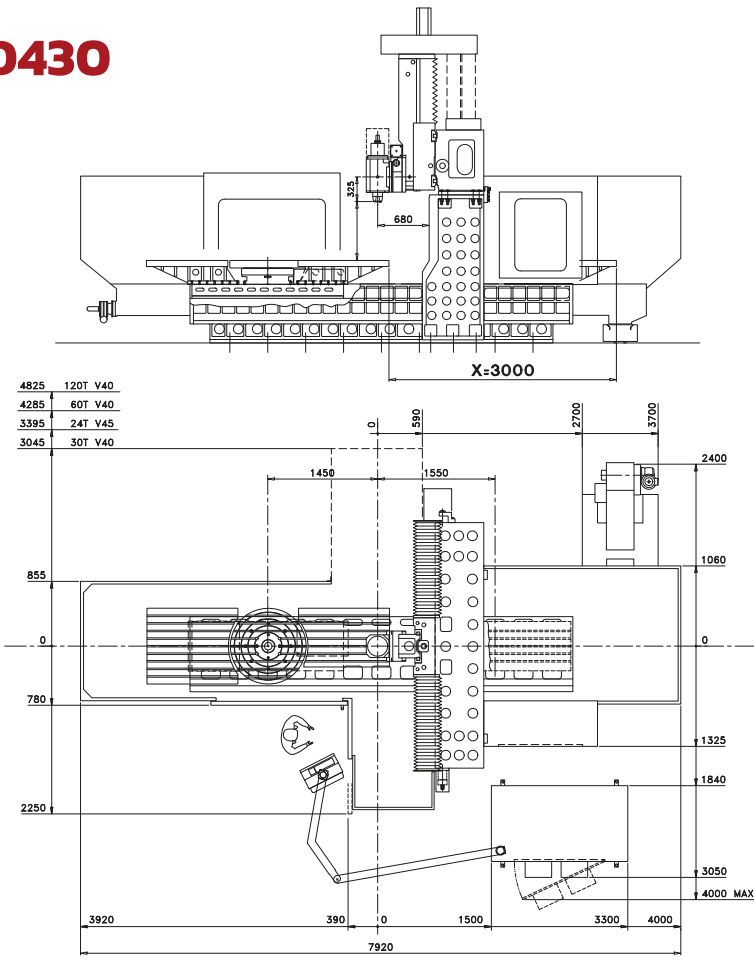

# D432

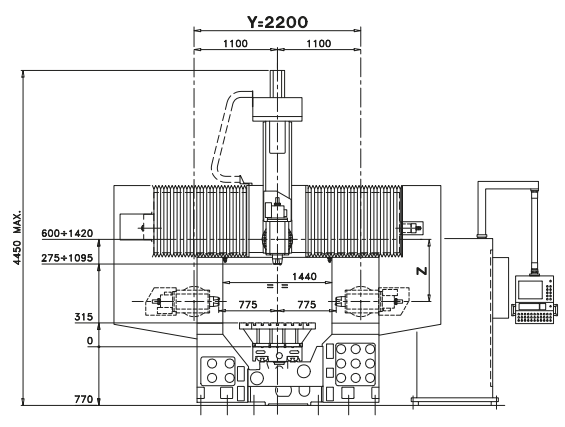
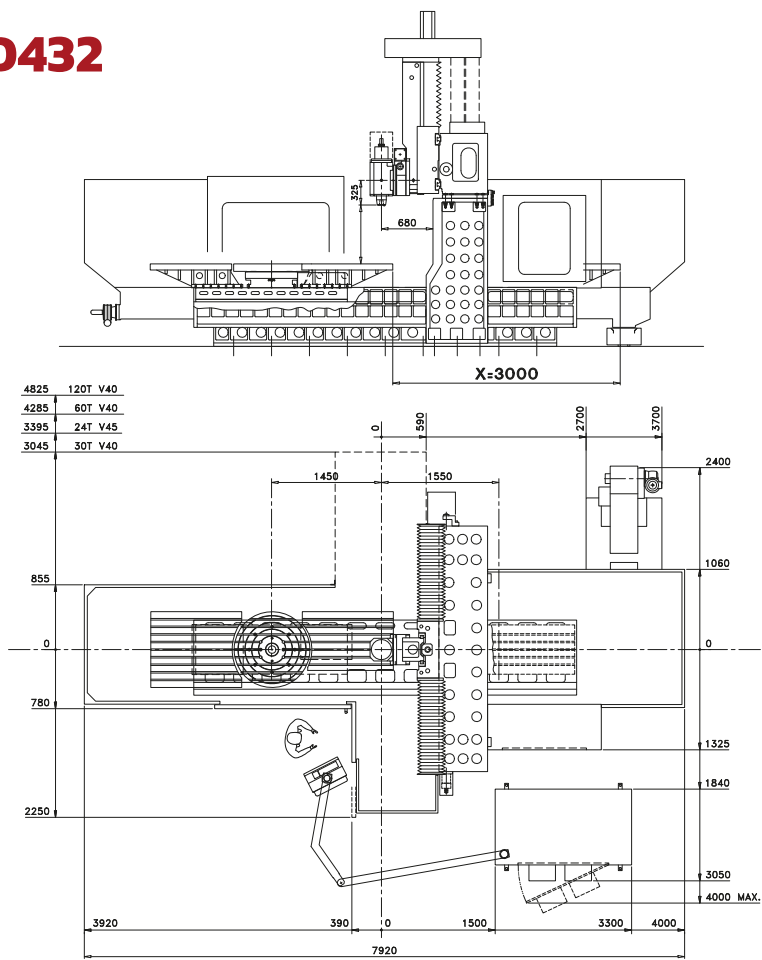



# 旋转工作台 ROTARY TABLE 蜗轮蜗杆/力矩电机 (铣削转台)

分辨率 Resolution	0.0001°
定位精度 Positioning accuracy	文件 doc. 099004
C轴速度 C axis speed (rpm)	0÷8/0÷80
扭矩 Working torque (Nm)	2200/1250
工件最大重量 Max workpiece weight (kg)	3200/3000

可配置车削转台，最大转速可达500rpm（载荷根据转台型号确定）

## 台面尺寸 FACEPLATE

型号 TYPE	
O42004	φ 1000x80
O42007	φ 1000x100
O42006	φ 1200x100
O42009	φ 1600x100

## 适用于D230 FOR D230

	型号 TYPE
台面尺寸 Faceplate φ1000x80	O42004
左侧固定工作台 Fixed left halftable	O41422
右侧固定工作台 Fixed right halftable	O41421

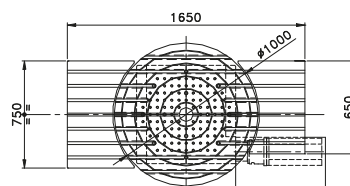

## 适用于D420/422 FOR D420/422

	型号 TYPE
台面尺寸 Faceplate φ1000x100	O42007
固定工作台 Fixed halftable	O41423

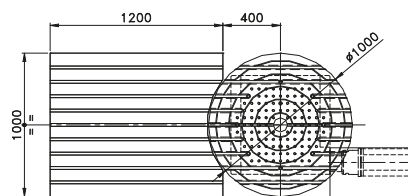

## 适用于D430/432 FOR D430/432

	型号 TYPE
台面尺寸 Faceplate φ1000x100	O42007
固定工作台 Fixed halftable	O41433

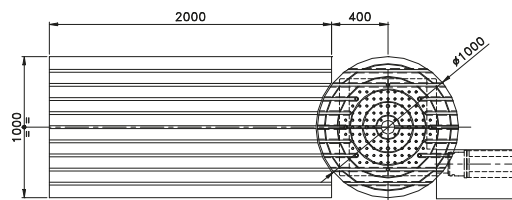

## 适用于D420/422 FOR D420/422

	型号 TYPE
台面尺寸 Faceplate φ1000x100	O42007
左侧固定工作台 Fixed left halftable	O41424
右侧固定工作台 Fixed right halftable	O41425

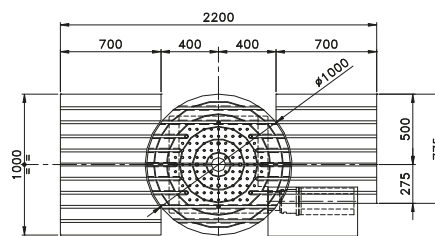

## 适用于D430/432 FOR D430/432

	型号 TYPE
台面尺寸 Faceplate φ1000x100	O42007
左侧固定工作台 Fixed left halftable	O41423
右侧固定工作台 Fixed right halftable	O41419

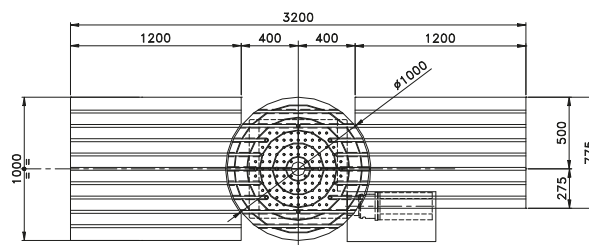



## 电主轴 *ELECTROSPINDLES*

14

C.B.Ferrari 所有机床配备自主设计并制造的电主轴，  
可以为其用户提供以下卓越的优势：

- 库存有充足的备用电主轴
- 响应时间短且主轴易于更换
- 低廉的维修费用
- 减少机床停机时间

陶瓷球轴承

集成同步电机

温度控制功能

液体冷却系统

刀具轴向热变形自动补偿

*C.B.Ferrari design and manufactures in house all the electrospindles its machines  
are equipped with, offering remarkable advantages to its customers:*

- *Spare spindles always available*
- *Easy replacement with minimum intervention time*
- *Low repair cost*
- *Reduced machine downtime*

*Ceramic ball bearings*

*Integrated synchronous motor*

*Temperature controlled operation*

*Liquid cooling system*

*Automatic compensation of thermal expansion along the tool axis*

20000 rpm  
28 kW  
63/83 Nm

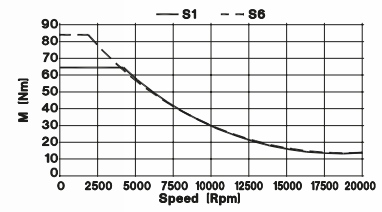
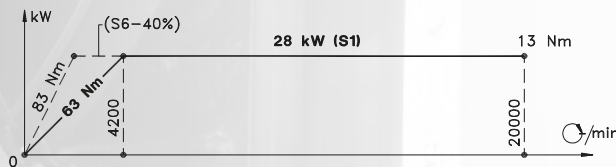

16000 rpm  
33 kW  
105/140 Nm

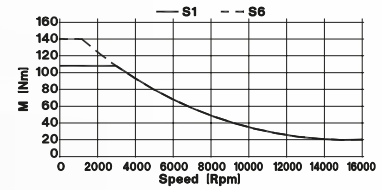
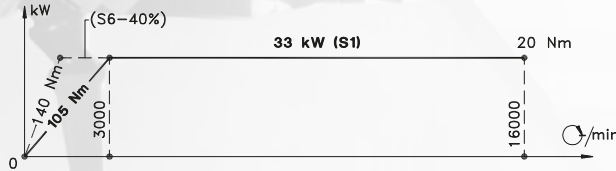

16000 rpm  
53/64 kW  
170/236 Nm

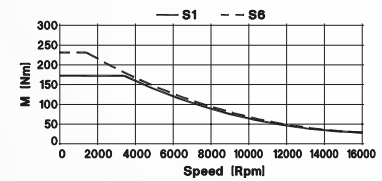
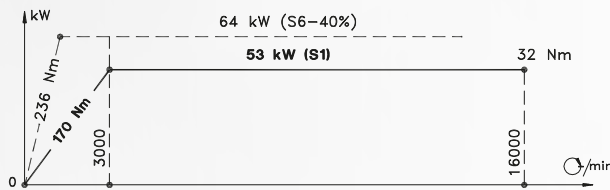

12000 rpm  
53/64 kW  
170/236 Nm

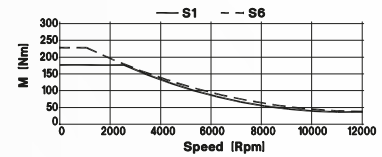
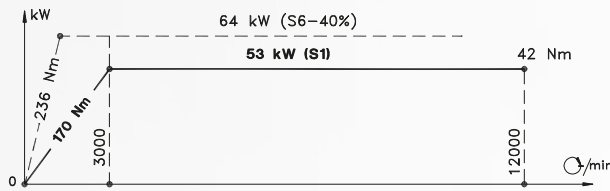

6500 rpm  
41/45 kW  
265/340 Nm

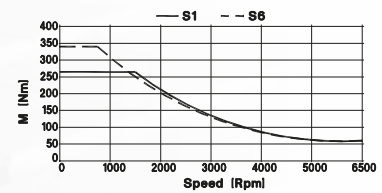
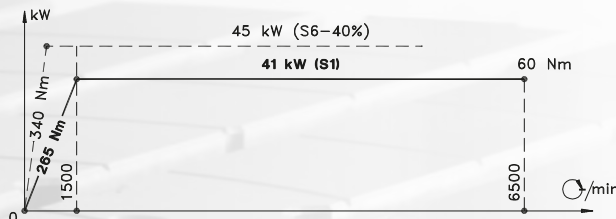

**连续摆动主轴头 ± 100°**  
**CONTINUOUS TILTING HEADS : ± 100°**

20.000 RPM	HSK A63	28 Kw	63/83 Nm	Type 051556
16.000 RPM	ISO V40	33 Kw	105/140 Nm	Type 050477
16.000 RPM	HSK A63	33 Kw	105/140 Nm	Type 050478
16.000 RPM	HSK A63	53/64 Kw	170/236 Nm	Type 051558
12.000 RPM	ISO V50	53/64 kW	170/236 Nm	Type 051551
6.500 RPM	ISO V50	41/45 kW	265/340 Nm	Type 050489
10.000 RPM	HSK A100	63/82 kW	300/410 Nm	Type 051578



## 配备双摆头的D系列 D SERIES WITH BI-ROTARY HEAD

在D422和D432型号上，可以通过配备由力矩电机驱动的双摆头以实现5轴联动。该双摆头拥有多种型号，单支撑或双支撑两种形式，以及多种主轴电机可选。

*On the D422 and D432 models, the 5-Axes configuration, can also be realized by installing a continuous bi-rotary tilting head with two torque axes. Different types of heads are available with single or double flange and various types of electrospindle motors.*



双支撑主轴头（样板）  
Example of head with double flange

### 产品参数 FEATURES

	D422	D432
<b>行程 • SLIDE TRAVELS</b>		
X - 轴 Longitudinal (mm)	2000	3000
Y - 轴 Cross (mm)	2200	2200
Z - 轴 Vertical (mm)	820	820
Z - 轴 可选 Vertical OPTION (mm)	1000	1000
<b>轴 • AXES</b>		
XYZ - 进给速度 Feed rates (m/min)	40	40
A - 旋转角度 Axis rotation	+/- 100°	+/- 100°
C - 旋转角度 Axis rotation	+/- 240°	+/- 240°
立柱间距 Passage through columns (mm)	1440	1440
立柱间距 可选 Passage through columns OPTION (mm)	1620	1620
<b>加工范围 • WORKING AREA</b>		
工作台尺寸 Table dimensions (mm)	2800x1200	3500x1200
工作台载荷 Table load (kg)	5000	5000
<b>电主轴 (样板) • ELECTROSPINDLE (example)</b>		
最大转速 Max speed (RPM)	20000	20000
功率 Power S1/S6 (40%) kW	50	50
扭矩 Torque S1/S6 (40%) Nm	90	90
刀柄样式 Spindle taper	HSK A 63	HSK A 63
<b>刀库 • TOOLS MAGAZINE</b>		
链条式刀库 Chain type	60/120	60/120
<b>重量 • WEIGHT</b>		
机床重量 Machine weight (kg)	22000	24000

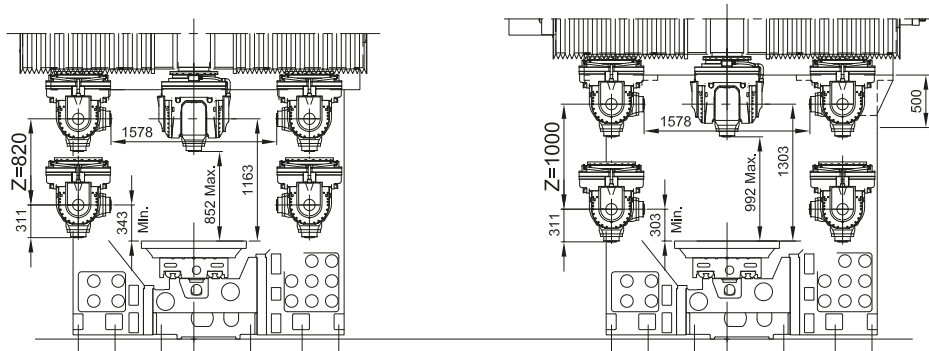
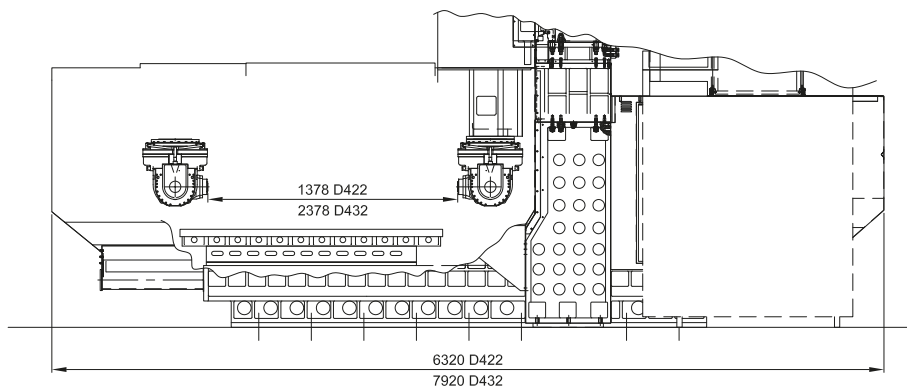
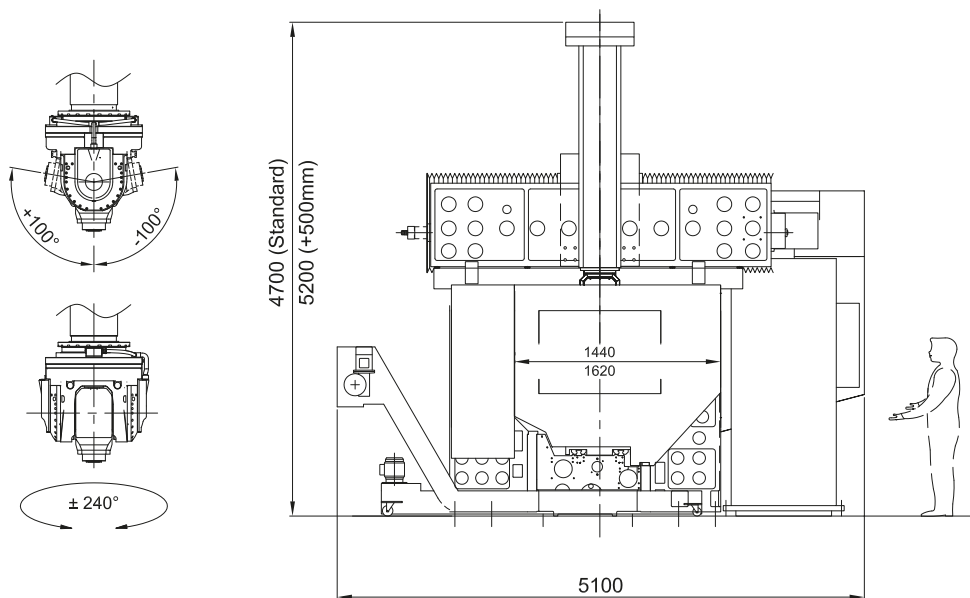

机床布局  
**D系列**  
**D SERIES**  
 MACHINE  
 LAYOUT

## 自动化解决方案 AUTOMATION SOLUTIONS

自动上下料的机械化系统  
机床可配置由C.B.Ferrari或其他供应商提供的自动化装载机械手。

*ROBOTIZED SYSTEM FOR THE AUTOMATIC PIECES CHANGE  
On the machining is possible to apply automatic loader, which can be produced by C.B.Ferrari  
or from external suppliers.*

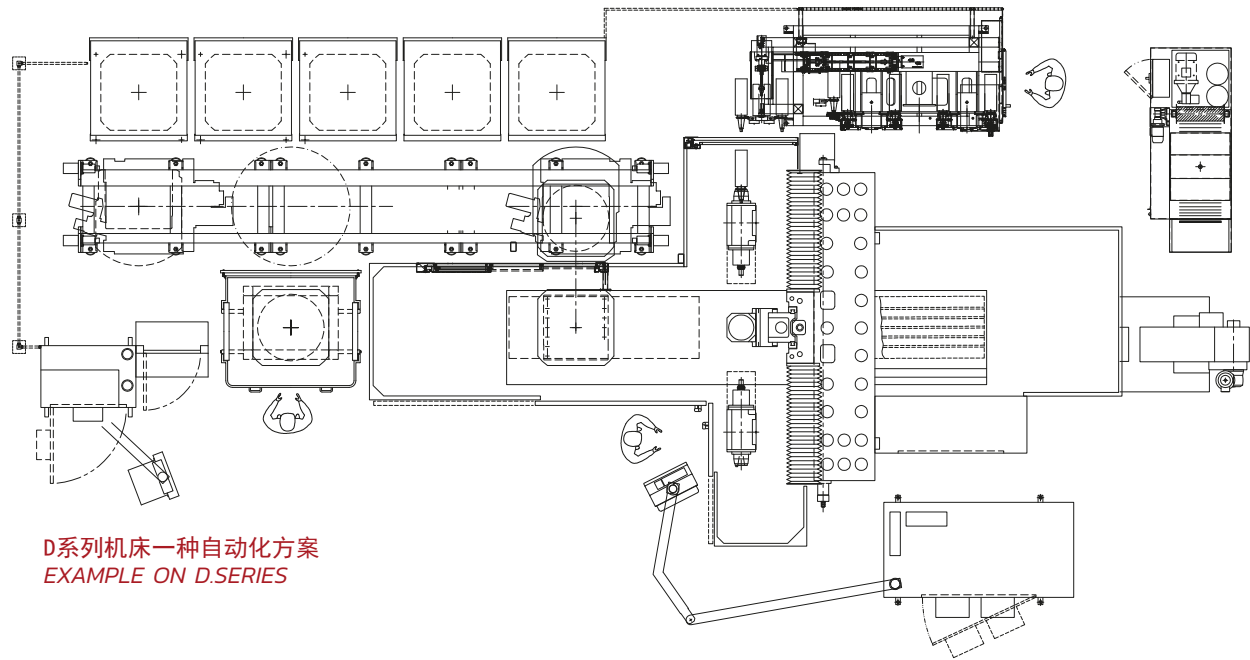

18

D系列机床一种自动化方案  
EXAMPLE ON D.SERIES

## 数控系统选项 AVAILABLE CONTROLS



西门子 840D SL

海德汉 TNC 640

## 绝对测量系统 ABSOLUTE MEASURING SYSTEM



所有回转轴标配海德汉绝对编码器  
分辨率达到0.0001°

*All rotary axes are equipped with Heidenhain  
absolute encoders. Resolution 0,0001°*

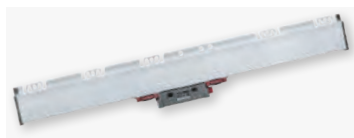

所有机床标配海德汉绝对光栅尺

*All machines are equipped with Heidenhain  
absolute linear scales.*

也可选用博世数控系统 Also available Bosch CNC.



## 配件一览 ACCESSORIES

机床可安装以下标准配件：

- 适用于钢件加工的排屑器
- 用于铝合金钛合金加工的排屑器
- 废气过滤器
- 75bar主轴中心出水
- 刀具气冷系统
- 刀具油气冷却系统
- 2D或3D接触式测头
- 接触式对刀仪
- 激光对刀仪
- 旋转视窗
- 根据要求可安装其他配件

*The machine can be equipped with the following STANDARD accessories:*

- Chips conveyor for Steel
- Chips conveyor for Aluminium/Titanium
- Exhaust filter
- Through spindle coolant system 75 bar
- Tool blower air system (standard)
- Tool blower air/oil system
- 2D or 3D Touch probe
- Touch tool setting device
- Laser tool setting device
- Spin window on door (rotoclear)
- *Other options available on request*



中心出水冷却单元 - 75 BAR  
460升水箱 - 鼓式过滤器

THROUGH SPINDLE COOLANT GROUP - 75 BAR  
460 lts tank - Drum filter



2D-3D 工件测量系统  
2D-3D control piece group

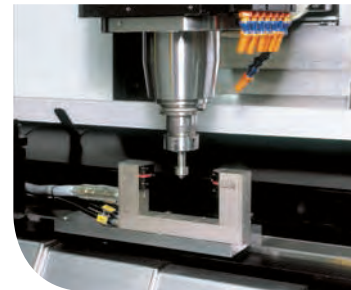

激光对刀仪  
Laser tools setting device



接触式对刀仪  
Contact tools setting device

可对旧机床的工作台、分度头  
以及电主轴进行升级。

*Possibility to update  
C.B.Ferrari used machines, with  
new tables, dividing heads  
and electrospindles.*



# C.B.Ferrari

**C.B. FERRARI S.r.l. a socio unico**  
*Società soggetta a direzione  
e coordinamento di  
Jingcheng Holding Europe GmbH  
Coburg, Germany*

## SEDE DI MORNAGO

Via Stazione, 116  
21020 **Mornago** (VA) - Italy  
Tel. +39 0331 903524  
Fax +39 0331 903642  
cbferrari@cbferrari.com

## SEDE DI MODENA

Strada Curtatona, 21  
41126 **Modena** - Italy  
Tel. +39 059 281460  
Fax +39 059 280113  
cbferrarimodena@cbferrari.com

## C.B.FERRARI CHINA

地址: 北京市顺义区顺西南路10号  
电话: +86 010 60496244  
传真: +86 010 60496243  
电子邮箱: cbferrari@cbferrari.com.cn

[www.cbfeerrari.com](http://www.cbfeerrari.com)

